

City of Lovington



REQUEST FOR SEALED BIDS

REPLACEMENT OF PUMPS AND MOTORS AT BOOSTER STATION #1

Bid Due Date & Time

November 18, 2019
10:00 a.m. (MST)

SUBMIT BID PROPOSALS TO:

Gary L. Chapman
Finance Director
City of Lovington
214 S. Love St.
Lovington, NM 88260
gchapman@lovington.org

**LEGAL NOTICE OF REQUEST FOR SEALED BIDS
LOVINGTON, NEW MEXICO**

**FOR REPLACEMENT OF PUMPS AND MOTORS AT BOOSTER STATION #1
DUE DATE: November 18, 2019**

The City of Lovington, New Mexico will receive sealed bid proposals at City Hall, 214 S. Love St., Lovington, New Mexico, on November 18, 2019 at 10:00 a.m. (MST) for the replacement of pumps and motors at Booster Station #1.

The Request for Bids, any future addenda, and all related information may be obtained from the City of Lovington's website at www.lovington.org under "Procurement" or by contacting the Finance Department, 214 S. Love St., Lovington, New Mexico 88260, (575) 396-2884, gchapman@lovington.org.

James R. Williams, City Manager

Publish in: **Lovington Leader – October 31, 2019 and November 7, 2019**

FACSIMILE AND ELECTRONIC PROPOSALS ARE NOT ACCEPTABLE

Pursuant to the provisions of the New Mexico State Purchasing Act, sealed bids, subject to the conditions herein, will be received at the Lovington City Hall, New Mexico until the date and time shown above, and thereafter immediately opened and read in public for furnishing the commodities and/or services listed in the attached specifications.

COMMODITY CODES:

Effective July 1, 2016, each state agency and local public body shall use the standardized classification codes developed by the state purchasing agent. (NMSA 1978 13-1-30.1)

Applicable classification codes for this proposal are:

5-DIGIT CODE	ITEM DESCRIPTION
72056	Pumps, Miscellaneous (Not Otherwise Classified)

INSTRUCTION TO BIDDERS

1. **Envelopes containing bids must be sealed and marked on the upper left hand corner with the name and address of the Respondent, the date and hour of opening, the name of bid proposal, and mailed or delivered to the before the time of opening.**
2. Samples of items, when required, must be furnished, free of expense, prior to the opening of bids, and, if not destroyed, will upon request of Respondent, be returned to the Respondent at its expense. Copy of the warranty must be included with proposal and must be for the maximum amount the manufacturer provides, if goods are warrantable.
3. Bids which are mailed, or otherwise delivered prior to the point of opening must contain the information detailed in Item 1 above and must be mailed or otherwise delivered to the **Finance Director, 214 South Love, Lovington, New Mexico, 88260**. This information shall be included on **ALL EXTERIOR PACKAGING**.
4. All prices should be stated in units or quantities specified, with packing and delivery charges included.
5. Time of proposed delivery must be stated in definite terms. If time varies for different items, the Respondent should so state.
6. Bids must be made out and signed in the corporate or other name of Respondent and must be fully and properly executed by an authorized person.
7. Bids must be submitted on the bid price submittal form attached. **Any prices pertaining to exceptions must be attached to the bid** (stapled, bound or secured otherwise). All exceptions must be submitted ten days prior to the bid opening date to the City so addenda may be issued to ensure a fair and competitive process. If the Respondent provides any options other than requested, these will not be acceptable.
8. Bids received later than the time and date specified will not be considered.
9. Amendments to or withdrawals of bids received later than the time and date set for proposal opening will not be considered.
10. Respondents or their representative may be present at the bid opening.
11. The Purchasing Agent reserves the right to amend and/or cancel the bid invitation prior to the time and date of the bid opening.
12. The Purchasing Agent reserves the right to correct any bid awarded erroneously as a result of a clerical error on the part of the City of Lovington.
13. In the event the Respondent is unable to submit a bid, the Purchasing Department would appreciate advising this office to that effect. Failure to submit proposals on three consecutive Invitations to respond will result in the removal of the Respondents name from the mailing list.

14. Respondents and/or vendors doing business with the City of Lovington must be in compliance with the Federal Civil Rights Act of 1964 and Title VII of the Act. Rev., 1979.
15. It will be the sole responsibility to the Respondents requesting consideration for Resident Preference at bid openings to submit to the State Purchasing Agent, the questionnaire for Resident Business or Contractor's Certification and to receive approval and a certification form prior to the proposal opening. Requests for consideration for Resident Business or Contractor's Preference after bid opening will not be considered.
16. All contracts solicited by competitive sealed proposals for the City of Lovington require that the bid amount exclude the applicable state gross receipts tax. As the City of Lovington is required to pay the applicable state gross receipts tax, all requests for payment shall include a separate amount on each billing reflecting the applicable tax. (13-1-108)
17. **All applicable state gross receipts tax charged to the City of Lovington shall be at the current rate at the time of the project. Respondents and/or vendors agree to report the gross receipts tax charged to the City of Lovington on New Mexico Taxation & Revenue Department form CRS- 1 and use Lovington as the municipality name in column A and 04-101 as the location code in column C.**
18. Any equipment supplied to the City of Lovington must comply with all requirements and standards as specified by the federal government's Occupational Safety and Health Act of 1971. All guards and protectors as well as appropriate markings must be in place before delivery. Items not meeting OSHA specifications will be refused. The supplier may be required, at its expense to provide training to municipal employees in the operation of this item and its maintenance, at the convenience of the City of Lovington.
19. **All respondents and/or vendors doing business with the City of Lovington must also provide IRS FORM W-9 (REV. JANUARY 2011 or DECEMBER 2011). Failure to do so may cause the proposal to be rejected by the City of Lovington.**
20. The City reserves the right to render payment of any invoices using the City's Procurement Card without incurring any penalty.

CONDITIONS AND BID OPENING PROCEDURES

1. The City of Lovington reserves the right to reject any and all bids, to waive an informality in bids, and unless otherwise specified by the Respondent, to accept any item on the bid.
2. In case of error in the extension of prices in the bid, the unit price will govern.
3. Any discount offered will be computed from the date of delivery or from the date a correct bill rendered on a proper voucher form and certified by the contractor is received, whichever date is latest.
4. The Procurement Code, Sections 13-1-28 through 13-1-199 NMSA 1978, imposes civil and criminal penalties for its violation. In addition, the New Mexico criminal statutes impose felony penalties for illegal bribes, gratuities and kickbacks.
5. It is the intent of these specifications to describe the minimum requirements. All portions not specifically mentioned which are required for a completion of the project, shall conform in design, strength, quality of material and workmanship to the highest standards of engineering practice.
6. All bids must be clearly marked on the outside of the envelope with the project name and opening date. Should a bid be opened prior to the official opening date due to the lack of a proper marking, it will be rejected.
7. All interested parties are invited to attend bid openings of the City of Lovington.
8. Bids will be opened and read aloud at precisely the time, the date and the place stipulated in the Request for Bids and in the legal notice published in the newspaper.
9. Bids will be opened and read aloud in front of whomsoever is present at the scheduled time and place.
10. Each bid will be evaluated by the Finance Director and the appropriate department or committee. The Respondent is to provide complete specifications. Acceptable exceptions to specifications will be determined by the Director of Purchasing with the aid of the appropriate department head.
11. The Finance Director and the department or committee will rule on any point needing clarification.
12. The apparent low Respondent, meeting specifications, will be determined by the Finance Director and the department or committee.
13. Respondents are advised to bear in mind that the low response obtained at the opening of the proposals may not be the proposal ultimately selected for the award. The successful respondent will be the one whose product is judged to best serve the interests of the City when price, product, safety, and delivery are considered.

14. A Respondents request for Resident Preference will be honored only when the provisions of Sections 13-1-21 and 13-1-22 of the State Purchasing Act have been met.
15. Do not submit alternate bids unless instructed to do so, as they will not be considered.
16. Notice is hereby given that the City Commission reserves the right to reject any and all bids received. In the case of ambiguity or lack of clarity, the right to determine the best bid or to reject same or to waive irregularities and technicalities.
17. Any requested literature and one complete copy of the bid, unless stated otherwise in the Request for Proposal, must be submitted with the bid.
18. All bids must be valid for a minimum of sixty (60) days after bid opening, unless otherwise stated in the bid sheet by the individual respondent or the City of Lovington.
19. All Respondents who are engaged in business within the municipal limits of the City, shall be licensed to do business by the City of Lovington.
20. This procurement is being done on behalf of the City of Lovington, its departments as well as other entities and agencies in general as provided for by law, at the discretion of the contracted vendor(s).
21. Pursuant to 13-4-11 (A) NMSA Annotated, state wage rates shall apply to any bid or proposal on construction or public works projects in excess of \$60,000.00. In addition all bidders and proposers shall comply with Federal wage rates on applicable projects.
22. Pursuant to 13-1-146 NMSA Annotated, a bid security or bond shall be required of bidders or offerors for construction contracts in excess of twenty-five thousand dollars (\$25,000). Bid security or bond in an amount equal to at least five percent (5%) of the amount bid shall be a bond provided by a surety company authorized to do business in the state of New Mexico, or the equivalent in cash.
23. Pursuant to 13-4-13.1 NMSA Annotated, in order to submit a proposal valued at more than sixty thousand dollars (\$60,000) in order to respond to a request for proposals or to be considered for award of any portion of a public works project greater than fifty thousand dollars (\$50,000) for a public works project that is subject to the Public Works Minimum Wage Act [13-4-10 NMSA 1978], the contractor, serving as a prime contractor or not, shall be registered with the labor and industrial division of the labor department.
24. Pursuant to 13-4-34 NMSA Annotated, (A) Any person submitting a bid shall in his bid set forth: (1) the name and the city or county of the place of business of each subcontractor under subcontract to the contractor who will perform work or labor or render service to the contractor in or about the construction of the public works construction project in an amount in excess of five thousand dollars (\$5,000); and (2) the category of the work that will be done by each subcontractor. The contractor shall list only one subcontractor for each category as defined by the contractor in his bid. (B) A bid submitted

by a contractor who fails to comply with the provisions of Subsection A of this section is a non-responsive bid which shall not be accepted by a using agency.

25. Pursuant to 13-4-38 NMSA Annotated, Failure to specify subcontractor: If a contractor fails to list a subcontractor in excess of the listing threshold and he does not state that no bid was received or that only one bid was received, he represents that he is fully qualified to perform that portion of the work himself and that he shall perform that portion of the work himself. If after the award of the contract the contractor subcontracts any portion of the work, except as provided in the Subcontractors Fair Practices Act [13-4- 31NMSA 1978], the contractor shall be guilty of violation of the Subcontractors Fair Practices Act and subject to the penalties provided in Section 13-4-41 NMSA 1978.

HOLD HARMLESS/INDEMNITY AGREEMENT

To the full extent permitted by law, Contractor shall defend, indemnify and hold harmless City, its employees, agents and officials, from any liability, claims, suits, actions, arbitration proceedings, administrative proceedings, regulatory proceedings, losses expenses or costs of any kind, whether actual, alleged or threatened, actual attorney fees incurred by City, court costs, interest, defense costs including expert witness fees and any other costs or expenses of any kind whatsoever incurred in relation to, as a consequence of or arising out of or in any way attributable in whole or in part to the performance of this agreement. All obligations under this provision are to be paid by Contractor as the City incurs them.

Without affecting the rights of City under any provision of this agreement or this section, Contractor shall not be required to indemnify and hold harmless City as set forth above for liability attributable to the sole fault of City, provided such sole fault is determined by agreement between the parties or the findings of a court of competent jurisdiction. This exception will apply only in instances where the City is shown to have been solely at fault and not in instances where Contractor is solely or partially at fault or in instances where City's fault accounts for only a percentage of the liability involved. In those instances, the obligation of Contractor will be all-inclusive and City will be indemnified for all liability incurred, even though a percentage of the liability is attributable to conduct of the City.

Contractor acknowledges that its obligation pursuant to this section extends to liability attributable to City, if that liability is less than the Sole fault of City. Contractor agrees to obtain executed indemnity agreements with provisions identical to those set forth here in this section from each and every subcontractor, sub-tier contractor or any other person or entity involved by, for, with or on behalf of contractor in the performance of this agreement. In the event Contractor fails to obtain such indemnity obligations from others as required here, Contractor agrees to be fully responsible according to the terms of this section. Failure of City to monitor compliance with these requirements imposes no additional obligations on City and will in no way act as a waiver of any rights hereunder. This obligation to indemnify and defend City as set forth herein is binding on the successors, assigns, or heirs of Contractor and shall survive the termination of this agreement or this section.

Any dispute leading to litigation must be settled in the jurisdiction of the Lea County, New Mexico Court system.

1.0 PURPOSE

The purpose of this Request for Sealed Bids is to solicit sealed proposals to establish a contract through competitive responses for the procurement of in replacement of three existing pumps and motors at Booster Station #1 which is a part of the Lovington Municipal Water distribution system. The pumps and motors will be required to meet the same specifications as the existing equipment.

2.0 PROJECT DESCRIPTION

Booster #1 contains 3 pumps with motors. This project will cause the replacement of all three pumps and motors. Listed below are the pumps and motors that are currently in use: This information is being provided to provide bidders a concept of what the existing conditions are. :

Pump make:	American Marsh
Pump model:	340 Series
Pump GPM:	1,500
Technical Specifications:	Attachment A
Motor make:	North American Electric
Motor model:	PE365T-75-4C
Motor voltage:	480
Motor HP:	75
Technical Specifications:	Attachment B

The above information is being provided to give bidders a concept of what the existing conditions are. It is expected that bidders will provide installation of the same or equal equipment.

This project will require the replacement of the three existing pumps and motors. The term replacement is defined as:

1. The removal of existing pumps and motors. The old equipment will be turned over to the City for disposal.
2. Installation of the new pumps and motors with the same or equal equipment. The specifications of the replacement pumps and motors must be provided in the response to the bid.
3. Connecting the motors to the existing power supply at the booster station.
4. All testing required prior to bring unit(s) on-line.
5. All other items required as the City expects this project to be turn-key, to include operations and maintenance training and a 365-day warranty on all work performed.

3.0 SPECIAL NOTES

1. In the event that this project exceeds \$60,000, a wage rate determination has been provided as demonstrated in Attachment C.

2. Pursuant to 13-1-146 NMSA 1978, annotated, a bid security or bond shall be required of bidders or offerors.
3. Pursuant to 13-4-34 NMSA 1978, annotated, bidders or offerors must submit the names and amount of work to be performed by any subcontractors on the provided form.
4. A performance bond will be required for this project.
5. Pursuant to 13-4-13.1 NMSA 1978, annotated, contractors must be registered with the labor department.
6. Respondents must attach copies of the following documents. Failure to provide these documents will result in the bid being determined as non-responsive:
 - a. NM Contractor's license
 - b. Workforce Solutions Registration
 - c. NM Resident Preference Certification from the New Mexico Taxation and Revenue Department.



City of Lovington

Bid Form

**REPLACEMENT OF PUMPS AND MOTORS AT BOOSTER STATION #1
DUE DATE: NOVEMBER 18, 2019**

NAME OF BIDDER: _____

ADDRESS: _____

TELEPHONE NO.: _____

EMAIL: _____

CONTRACTOR LICENSE #: _____

BID AMOUNT: _____

Attach specifications of equipment to be installed to this bid form

The City of Lovington reserves the right to waive any irregularities an award, or not to award, in the best interests of the City. The City is held harmless and is indemnified for the loss and/or misplacement of bid submittals. The bidder is required to utilize this form. Signature is required and reflects agreement, by the bidder, to the terms of this document.

SIGNATURE OF BIDDER: _____

**Mail or deliver to City Hall at 214 S. Love St., Lovington, NM 88260
Deadline: November 18, 2019 by 10:00 a.m. (MST)**

**OPTIONS, EXCEPTIONS, OR VARIATIONS
CITY OF LOVINGTON, NEW MEXICO**

FOR REPLACEMENT OF PUMPS AND MOTORS AT BOOSTER STATION #1

DUE DATE: NOVEMBER 18, 2019 at 10:00 a.m. (MST)

Please state each and every option, exception, or variation to the specifications (if any) for the service(s) or item(s) offered. All exceptions must be submitted to the City ten days in advance of the bid opening date so addenda may be issued to ensure a fair and competitive bid process. Please sign below and return with your offer.

1. THERE ARE OPTIONS, EXCEPTIONS OR VARIATIONS. _____
Signature

2. THERE ARE NO OPTIONS, ETC. LISTED. The services offered on the Request for Sealed bids meet or exceed all specifications, terms, and conditions as described in said Request for Sealed Bids without exceptions. I understand services not meeting all specifications, terms, and conditions will be rejected and all costs will be borne by the seller.

Signature

CAMPAIGN CONTRIBUTION DISCLOSURE FORM

Pursuant to NMSA 1978, § 13-1-191.1 (2006), any person seeking to enter into a contract with any state agency or local public body **for professional services, a design and build project delivery system, or the design and installation of measures the primary purpose of which is to conserve natural resources** must file this form with that state agency or local public body. This form must be filed even if the contract qualifies as a small purchase or a sole source contract. The prospective contractor must disclose whether they, a family member or a representative of the prospective contractor has made a campaign contribution to an applicable public official of the state or a local public body during the two years prior to the date on which the contractor submits a proposal or, in the case of a sole source or small purchase contract, the two years prior to the date the contractor signs the contract, if the aggregate total of contributions given by the prospective contractor, a family member or a representative of the prospective contractor to the public official exceeds two hundred and fifty dollars (\$250) over the two year period.

Furthermore, the state agency or local public body shall void an executed contract or cancel a solicitation or proposed award for a proposed contract if: 1) a prospective contractor, a family member of the prospective contractor, or a representative of the prospective contractor gives a campaign contribution or other thing of value to an applicable public official or the applicable public official's employees during the pendency of the procurement process or 2) a prospective contractor fails to submit a fully completed disclosure statement pursuant to the law.

THIS FORM MUST BE FILED BY ANY PROSPECTIVE CONTRACTOR WHETHER OR NOT THEY, THEIR FAMILY MEMBER, OR THEIR REPRESENTATIVE HAS MADE ANY CONTRIBUTIONS SUBJECT TO DISCLOSURE.

The following definitions apply:

"Applicable public official" means a person elected to an office or a person appointed to complete a term of an elected office, who has the authority to award or influence the award of the contract for which the prospective contractor is submitting a competitive sealed proposal or who has the authority to negotiate a sole source or small purchase contract that may be awarded without submission of a sealed competitive proposal.

"Campaign Contribution" means a gift, subscription, loan, advance or deposit of money or other thing of value, including the estimated value of an in-kind contribution, that is made to or received by an applicable public official or any person authorized to raise, collect or expend contributions on that official's behalf for the purpose of electing the official to statewide or local office. "Campaign Contribution" includes the payment of a debt incurred in an election campaign, but does not include the value of services provided without compensation or unreimbursed travel or other personal expenses of individuals who volunteer a portion or all of their time on behalf of a candidate or political committee, nor does it include the administrative or solicitation expenses of a political committee that are paid by an organization that sponsors the committee.

"Family member" means spouse, father, mother, child, father-in-law, mother-in-law, daughter-in-law or son-in-law.

"Pendency of the procurement process" means the time period commencing with the public notice of the request for proposals and ending with the award of the contract or the cancellation of the request for proposals.

"Person" means any corporation, partnership, individual, joint venture, association or any other private legal entity.

"Prospective contractor" means a person who is subject to the competitive sealed proposal process set forth in the Procurement Code or is not required to submit a competitive sealed proposal because that person qualifies for a sole source or a small purchase contract.

"Representative of a prospective contractor" means an officer or director of a corporation, a member or manager of a limited liability corporation, a partner of a partnership or a trustee of a trust of the prospective contractor.

DISCLOSURE OF CONTRIBUTIONS:

Contribution Made By: _____

Relation to Prospective Contractor: _____

Name of Applicable Public Official: _____

Date Contribution(s) Made: _____

Amount(s) of Contribution(s): _____

Nature of Contribution(s): _____

Purpose of Contribution(s): _____

(Attach extra pages if necessary)

Signature

Date

Title (position)

NO CONTRIBUTIONS IN THE AGGREGATE TOTAL OVER TWO HUNDRED FIFTY DOLLARS (\$250) WERE MADE to an applicable public official by me, a family member, or representative.

Signature

Date

Title (position)

Veterans Preference Certification

_____ (Name of Business) hereby certifies the following in regard to application of the resident veteran preference to this formal request for proposals process:

Please check one box only:

- I declare under penalty of perjury that my business prior year revenue starting January 1 ending December 31 is less than \$3M allowing me the 10% preference discount on this bid or proposal. I understand that knowingly giving false or misleading information about this fact constitutes a crime.

"I agree to submit a report, or reports, to the State Purchasing Division of the General Services Department declaring under penalty of perjury that during the last calendar year starting January 1 ending December 31, the following to be true and accurate:

"In conjunction with this procurement and the requirements of this business' application for a Resident Veteran Business Preference/Resident Veteran Contractor Preference under Sections 13-1-21 or 13-1-22 NMSA 1978, when awarded a contract which was on the basis of having such veterans preference, I agree to report to the State Purchasing Division of the General Services Department the awarded amount involved. I will indicate in the report the award amount as a purchase from a public body or as a public works contract from a public body as the case may be."

"I declare under penalty of perjury that this statement is true to the best of my knowledge. I understand that giving false or misleading statements about material fact regarding this matter constitutes a crime."

(signature of Business Representative)*

(Date)

*Must be an authorized signatory for the Business.

The representation made in checking the boxes constitutes a material representation by the business that is subject to protest and may result in denial of an award or unaward of the procurement involved if the statements are proven incorrect.

ATTACHMENT A



**PRODUCT BULLETIN
MODEL HD DOUBLE SUCTION**

Applications

American-Marsh Model HD Double Suction pumps are used in a variety of industries. These rugged and efficient centrifugal pumps are designed for long life and low operational costs. Each model has a removable rotating assembly that can be serviced without disturbing the driver or piping. Models are available in a packed or mechanically sealed orientation for use in demanding applications.

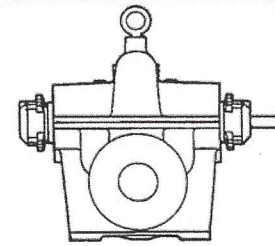

Material Specifications

PART	CONSTRUCTION			
	BRONZE FITTED	IRON FITTED	NI-RESIST FITTED	316SS FITTED
Casing	Cast Iron	Cast Iron	Cast Iron	Cast Iron
Impeller	Bronze	Cast Iron	Ni-Resist	316 Stainless Steel
Shaft Sleeve	Bronze	Bronze	316 Stainless Steel	316 Stainless Steel
Stuffing Box	Cast Iron	Cast Iron	Cast Iron	Cast Iron
Shaft	420 Stainless Steel	420 Stainless Steel	420 Stainless Steel	410 Stainless Steel
Case Wear Ring	Bronze	Cast Iron	Ni-Resist	316 Stainless Steel
Bolts, Studs & Nuts	Steel	Steel	Steel	Steel
Packing	Graphite Braid	Graphite Braid	Graphite Braid	Graphite Braid
Mechanical Seal	Carbon/Si-C/Buna	Carbon/Si-C/Buna	Carbon/Si-C/Buna	Carbon/Si-C/Buna

MODEL HD SPECIFICATIONS

Casing: The casing is of high tensile cast iron or other specified material. It is of the volute type with double suction, split on the horizontal centerline with the suction and discharge nozzles cast integral with the lower half. Suction and discharge nozzles are casted of 250 psi dimensions and all models feature a 250 psi case working pressure. Removal of the upper casing gives complete access to the interior of the pump without disturbing piping connections or pump alignment. The casing utilizes *Thru-Bore* lineboring technology simplifying the machining operation and allows the advantage of using only a few modular rotating assemblies. The *Thru-Bore* feature allows for the complete removal and replacement of the stuffing boxes without replacing the casing.

Impeller: The impeller is of the double suction, enclosed, non-overloading type. It is made of bronze, or other specified material, machined and polished all over and dynamically and hydraulically balanced. The impeller is keyed to the shaft and secured by locknuts. It is adjustable for position.

Case Wear Rings: Case wear rings are made of bronze or other specified material. They are designed with a large wearing surface with the diameter at wearing surface reduced to a minimum, and are firmly secured in the casing by dowel pins.

Shaft: The shaft is of 420 stainless steel, ground and polished to a smooth surface. It is designed for extra stiffness to avoid all critical speeds in operation, and is threaded for bearing and impeller lock nuts. The portion of the shaft that is exposed to the pumped fluid is covered

with renewable bronze shaft sleeves screwed on against the impeller with right and left hand threads which cannot work loose during operation. Shaft sleeves have external o-rings, in lieu of internal o-rings, to stop leakage of product.

Stuffing Boxes/Seal Chambers: The stuffing boxes/seal chambers are extra deep, being designed for packing and lantern ring or mechanical seals. Under each stuffing box is a drip pocket with tapped drain outlet. The stuffing boxes/seal chambers are completely removable and replaceable.

Bearings: Both the inboard and outboard ball bearings are of the single row, deep groove type, precision grade, with cartridge mounting, permitting the removal of the shaft without exposing or disturbing the bearing assembly. They are of extra large capacity for both radial and thrust loads. The outboard bearing is confined rigidly in the bearing housing to take end thrust, while the inboard bearing is set with sufficient clearance to allow for shaft expansion. All bearings are sized to maintain a minimum of 50,000 hour bearing life. Each bearing is designed for grease lubrication and is provided with a water slinger to prevent leakage from the stuffing box into the bearing. A zerk fitting is furnished for each bearing. Each bearing housing is sealed from water leakage by the use of an oil lip seal.

Both bearings can be removed and replaced without removing the rotating assembly from the pump, greatly simplifying the repair process.

INDUSTRIAL
 Process, Petrochemical, Leachate Recovery
COMMERCIAL
 HVAC, Booster, Condensate Return, Supply Water, Reverse Osmosis
MUNICIPAL
 Quench Water, Filtration, Transfer, Filter Backwash, Supply Water
PRODUCT BULLETIN
MODEL HD DOUBLE SUCTION

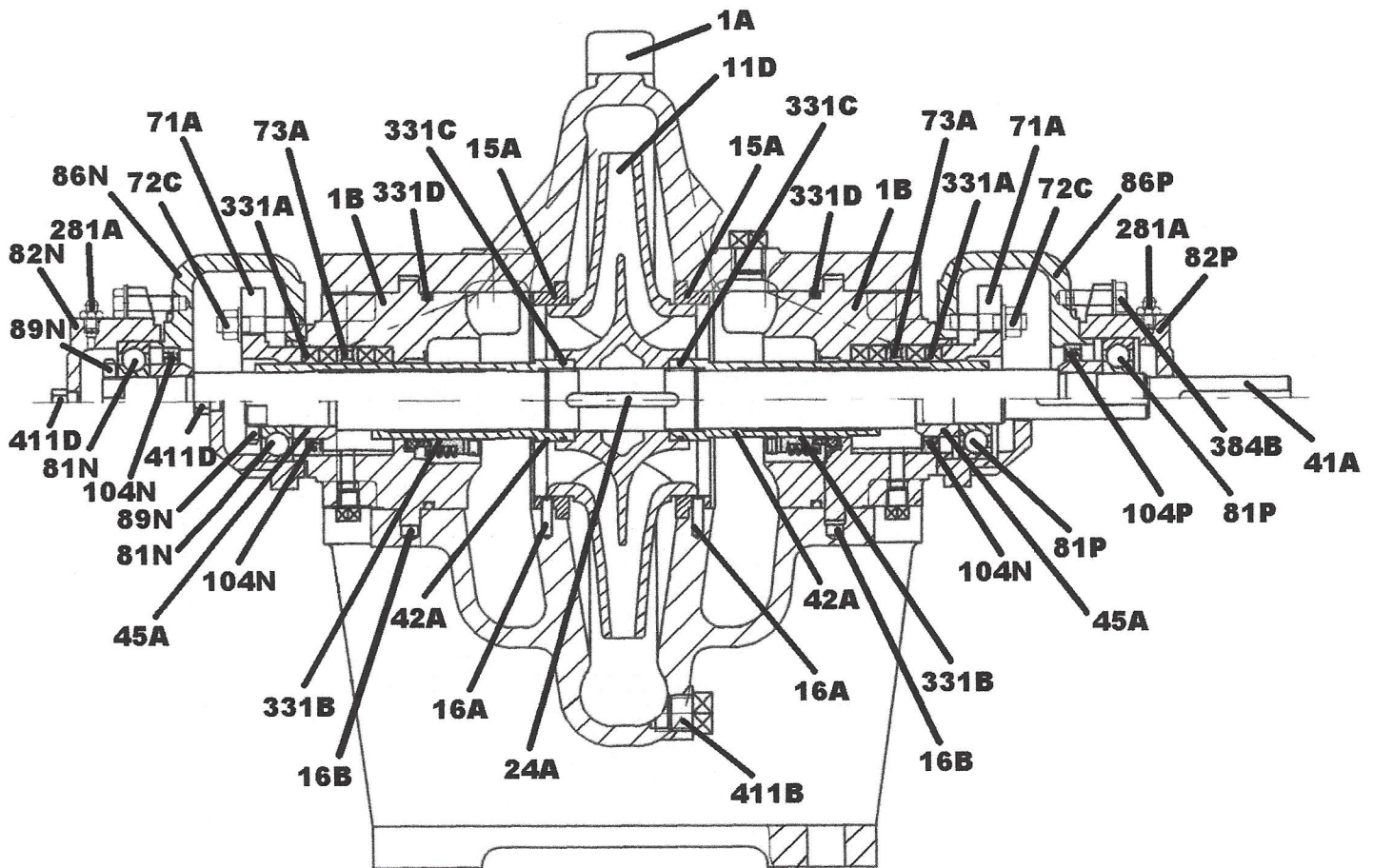

HD Sectional Drawing

Item Number	Item Description	Num. Req.
1A	Casing, Complete	1
1B	Stuffing Box	2
11D	Impeller	1
15A	Case Wear Ring	2
16A	Dowel Pin	2
16B	Dowel Pin	2
24A	Impeller Key	1
41A	Shaft	1
42A	Shaft Sleeve	2
45A	Bearing Adapter	2
71A	Gland Assembly, Complete	2
72C	Hinge Bolt	4
73A	Lantern Ring	2
81N	Outboard Bearing, Thrust	1
81P	Inboard Bearing, Radial	1
82N	Bearing Housing, Outboard	1
82P	Bearing Housing, Inboard	1

Item Number	Item Description	Num. Req.
86N	Bearing Arm, Outboard	1
86P	Bearing Arm, Inboard	1
89N	Locknut, Outboard	1
104N	Lip Seal, Outboard	1
104P	Lip Seal, Inboard	1
281A	Zerk Fitting	2
331A	Packing	1 Set
331B	Mechanical Seal	2
331C	Shaft Sleeve O-Ring	2
331D	Stuffing Box O-Ring	2
353A*	Case Gasket	1
381B*	Casing Capscrew	Varies
384B	Bearing Housing Capscrews	8
411A	Plug, Vent	1
411B	Plug, Drain	1
411D	Plug, Bearing Housing	1

* Not shown in sectional.

Recommended spare parts are in **BOLD**.

ATTACHMENT A

340 SERIES HD SPLIT CASE PERFORMANCE CURVES - 1800 RPM

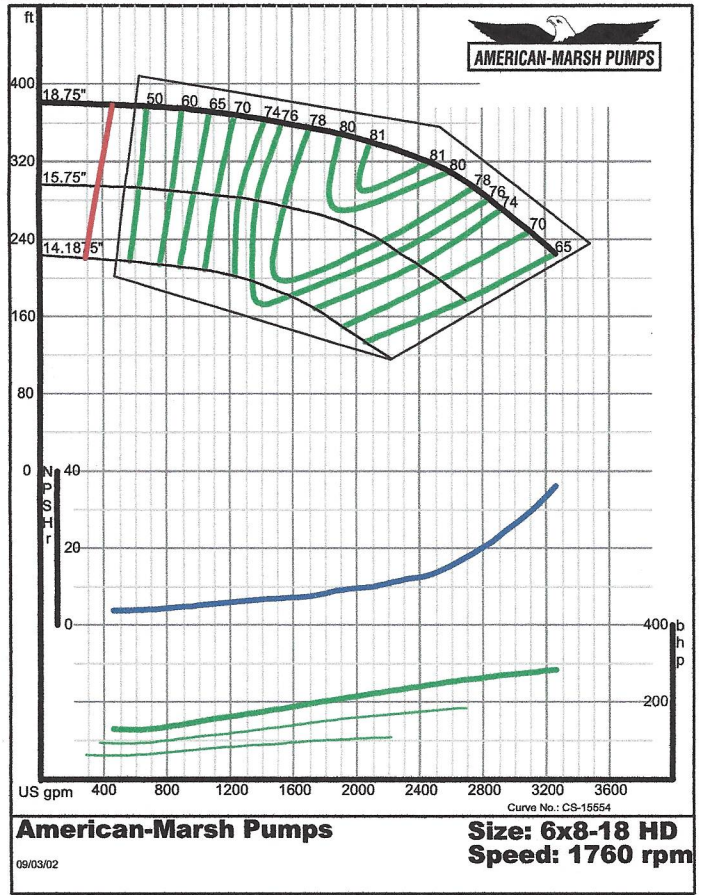
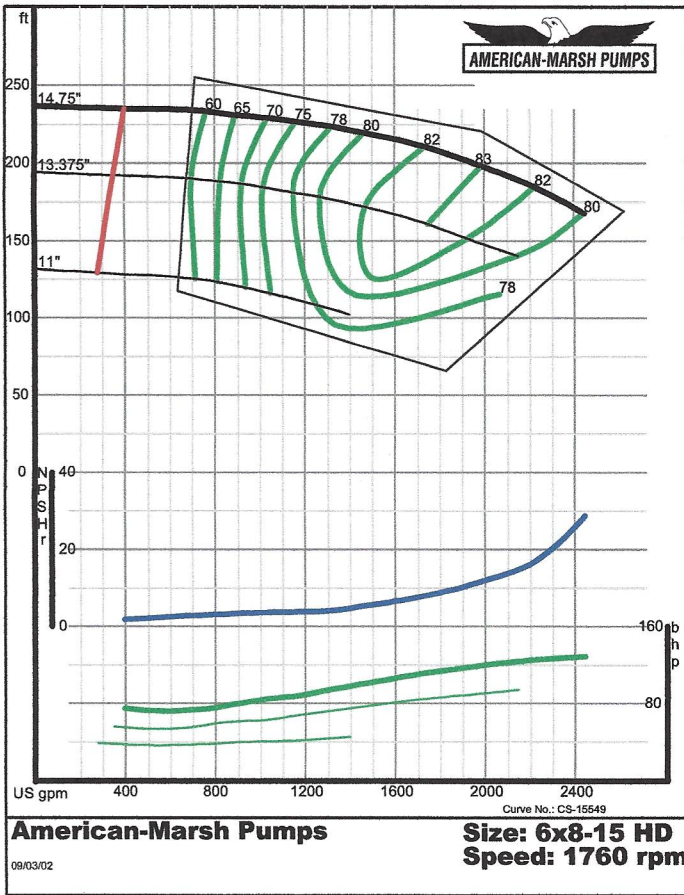

340 SERIES HD SPLIT CASE PERFORMANCE CURVES - 1800 RPM

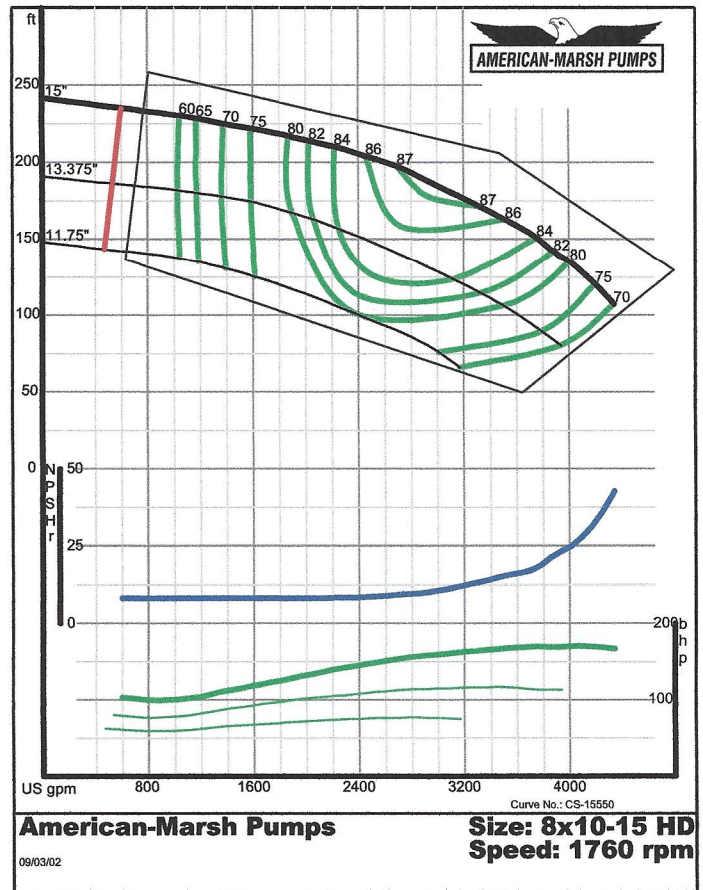
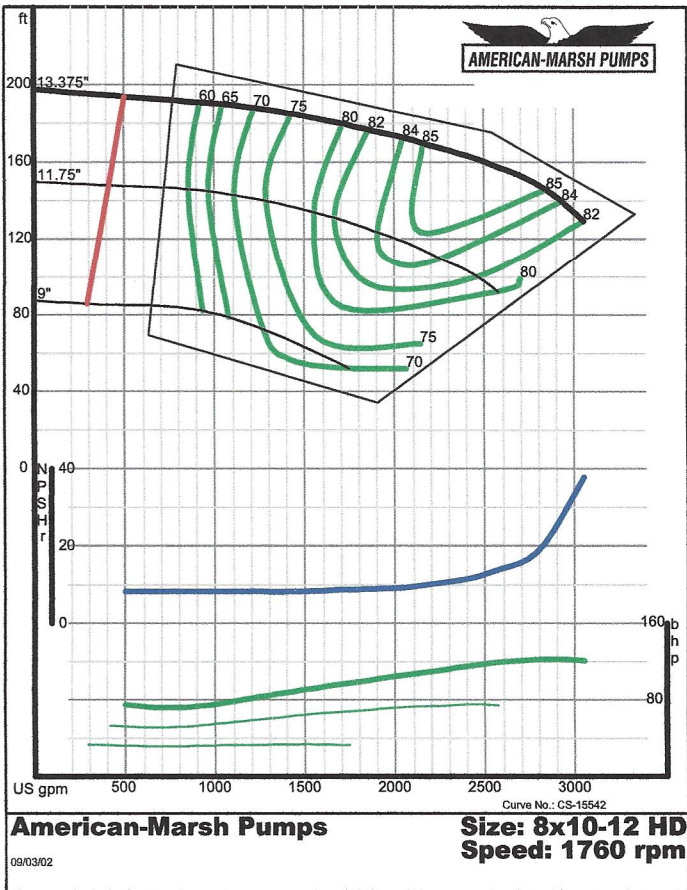

USE THE 8X10X12 PERFORMANCE CURVE

ATTACHMENT B



PE365T-75-4C

PREMIUM CRUSHER DESIGN MOTOR

Inverter Rated (10:1 Variable Torque; 5:1 Constant Torque)

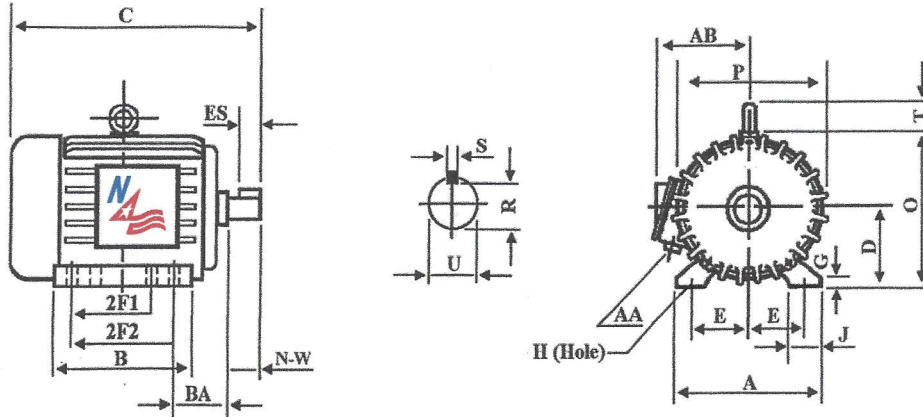

DIMENSIONS – INCHES

A	B	C	D	E	2F1	2F2	G	H	J	O
17.1	15.4	33.5	9.0	7.0	11.25	12.25	1.1	.66	2.953	18.1
P	R	S	T	U	ES	AA	AB	BA	N-W	Mount
17.6	2.021	.625	2.6	2.375	4.28	3.0	14.6	5.88	5.88	F1

PERFORMANCE DATA

Three Phase – 60Hz - 208-230/460V – NEMA Design C - Max. Ambient: 40° C

HP	Speed	Frame	NEMA Code	Efficiency (%)			Power Factor (%)			Torque (ft-lb)		
				100%	75%	50%	100%	75%	50%	FLT	BDT%	LRT%
75	1780	365T	G	94.1	93.5	93.2	86.0	87.0	83.0	222	260	210
Amps (460V)		DE Bearing	ODE Bearing	Insulation Class	Enclosure Type	Service Factor	Weight (lbs)					
FLA	LRA											
88.6	542	6313	6313	F	TEFC	1.15	745					



North American Electric, Inc. 350 Vaiden Drive, Hernando, MS 38632
 Toll Free: 1-800-884-0405 Phone: 662-429-8049 Fax: 662-429-8546
www.naemotors.com

ATTACHMENT C



LABOR RELATIONS DIVISION

401 Broadway NE
 Albuquerque, NM 87102
 Phone: 505-841-4400
 Fax: 505-841-4424

226 South Alameda Blvd
 Las Cruces, NM 88005
 Phone: 575-524-6195
 Fax: 575-524-6194

WWW.DWS.STATE.NM.US

1596 Pacheco St, Suite 103
 Santa Fe, NM 87505
 Phone: 505-827-6817
 Fax: 505-827-9676

Wage Decision Approval Summary

1) Project Title: Booster Station #1 Pumps and Motors Replacement
 Requested Date: 10/08/2019
 Approved Date: 10/09/2019
 Approved Wage Decision Number: LE-19-1896-A

Wage Decision Expiration Date for Bids: 02/06/2020

2) Physical Location of Jobsite for Project:
 Job Site Address: 7300 Lovington Highway
 Job Site City: Lovington
 Job Site County: Lea

3) Contracting Agency Name (Department or Bureau): City of Lovington
 Contracting Agency Contact's Name: James Williams
 Contracting Agency Contact's Phone: (575) 396-2884 Ext. 303

4) Estimated Contract Award Date: 11/30/2019

5) Estimated total project cost: \$60,000.00
 a. Are any federal funds involved?: No
 b. Does this project involve a building?: No
 c. Is this part of a larger plan for construction on or appurtenant to the property that is subject to this project?: No
 d. Are there any other Public Works Wage Decisions related to this project?: No
 e. What is the ultimate purpose or functional use of the construction once it is completed?: Replacement of three 1,500 GPM water system pumps and three motors (75hp/480 volt)

6) Classifications of Construction:

Classification Type and Cost Total	Description
Highway/Utilities (A) Cost: \$60,000.00	Replacement of three 1,500 GPM water system pumps and three motors (75hp/480 volt)

**LABOR RELATIONS DIVISION**

401 Broadway NE
Albuquerque, NM 87102
Phone: 505-841-4400
Fax: 505-841-4424

226 South Alameda Blvd
Las Cruces, NM 88005
Phone: 575-524-6195
Fax: 575-524-6194

WWW.DWS.STATE.NM.US

1596 Pacheco St, Suite 103
Santa Fe, NM 87505
Phone: 505-827-6817
Fax: 505-827-9676

ATTACHMENT C**PUBLIC WORKS PROJECT REQUIREMENTS**

As a participant in a Public Works project valued at more than \$60,000 in the state of New Mexico, the following list addresses many of the responsibilities that are defined by statute or regulation to each project stakeholder.

Contracting Agency

- Ensure that all contractors wishing to bid on a Public Works project when the project is \$60,000 or more are actively registered with the Public Works and Apprenticeship Application (PWAA) website: <http://www.dws.state.nm.us/pwaa> (Contractor Registration) prior to bidding.
- Please submit Notice of Award (NOA) and Subcontractor List(s) to the PWAA website promptly after the project is awarded.
- Please update the Subcontractor List(s) on the PWAA website whenever changes occur.
- All sub-contractors and tiers (excluding professional services) regardless of contract amount must be listed on the Subcontractor List and must adhere to the Public Works Minimum Wage Act.
- Ninety days after project completion please go into the PWAA system and close the project. Only contracting agencies are allowed to close the project. Agents or contractors are not allowed to close projects.

General Contractor

- Provide a complete Subcontractor List and Statements of Intent (SOI) to Pay Prevailing Wages for all contractors, regardless of amount of work, to the contracting agency within 3 (three) days of award.
- Ensure that all subcontractors wishing to bid on a Public Works project have an active Contractor Registration with the Public Works and Apprenticeship Application (PWAA) website: <http://www.dws.state.nm.us/pwaa> prior to bidding when their bid will exceed \$60,000.
- Make certain the Public Works Apprentice and Training Act contributions are paid either to an approved Apprenticeship Program or to the Public Works Apprentice and Training Fund.
- Confirm the Wage Rate poster, provided in PWAA, is displayed at the job site in an easily accessible place.
- When the project has been completed, make sure the Affidavits of Wages Paid (AWP) are sent to the contracting agency.
- All subcontractors and tiers (excluding professional services) regardless of contract amount must pay prevailing wages, be listed on the Subcontractor List, and adhere to the Public Works Minimum Wage Act.

TYPE "A" - STREET, HIGHWAY, UTILITY & LIGHT ENGINEERING

Effective January 1, 2019

ATTACHMENT C

Trade Classification	Base Rate	Fringe Rate
Bricklayer/Blocklayer/Stonemason	23.78	9.08
Carpenter/Lather	24.08	10.84
Cement Mason	17.42	6.61
Ironworker	26.50	16.20
Painter (Brush/Roller/Spray)	17.00	6.78
Plumber/Pipefitter	29.45	12.37
Electricians (outside)		
Groundman	22.81	11.93
Equipment Operator	32.73	14.51
Lineman/Wireman or Tech	38.51	16.02
Cable Splicer	42.36	17.01
Laborers		
Group I	11.81	5.88
Group II	12.11	5.88
Group III	12.51	5.88
Group IV	12.76	5.88
Operators		
Group I	18.60	5.94
Group II	19.52	5.94
Group III	19.62	5.94
Group IV	19.73	5.94
Group V	19.83	5.94
Group VI	20.01	5.94
Group VII	20.17	5.94
Group VIII	20.46	5.94
Group IX	27.88	5.94
Group X	31.10	5.94
Truck Drivers		
Group I	16.15	7.52
Group II	16.15	7.52
Group III	16.15	7.52
Group IV	16.15	7.52
Group V	16.15	7.52
Group VI	16.15	7.52
Group VII	16.15	7.52
Group VIII	16.21	7.52
Group IX	18.15	7.52

NOTE: All contractors are required to pay SUBSISTENCE, ZONE AND INCENTIVE PAY according to the particular trade. Details are located in a PDF attachment at